

# MATH MAMMOTH

## Grade 6-B

### Complete Worktext

- Percent
- Geometry:  
angles, similar  
& congruent  
figures, area,  
and volume
- Integers &  
coordinates
- Probability
- Statistics



By Maria Miller

[www.MathMammoth.com](http://www.MathMammoth.com)

---

# Contents

## Chapter 6: Percent

Introduction .....	5
Percent .....	9
Percentage of a Number .....	13
Percentage of a Number: Using Decimals .....	16
Discounts .....	19
Sales Tax .....	21
Practice with Percent .....	23
“Backwards” Questions with Percent .....	26
Tenth of a Percent .....	27
Ratios, Fractions and Percent .....	29
Circle Graphs .....	32
Percent of Change .....	34
Percent of Change, Part 2 .....	37
Percent of Change: Applications .....	39
Comparisons with Percent .....	41
Review Percent .....	45

## Chapter 7: Geometry

Introduction .....	49
Angle Relationships .....	55
Classify Triangles .....	59
Angles in a Triangle .....	61
Quadrilaterals Review .....	63
Angles in Polygons .....	65
Drawing Problems .....	67
Congruent and Similar Figures .....	69
Similar Figures and Scale Ratio .....	71
Congruent Transformations .....	74
Transformations in the Coordinate Grid .....	76
Review: Area of Polygons 1 .....	80
Review: Area of Polygons 2 .....	83
Circumference of a Circle .....	85
Area of a Circle .....	88

Area and Perimeter Problems .....	91
Converting Between Metric Area Units .....	94
Converting Between Customary Area Units .....	98
Volume of Prisms and Cylinders .....	102
Volume of Pyramids and Cones .....	105
Surface Area .....	108
Converting Between Units of Volume .....	111
Geometry Review .....	113

### **Chapter 8: Integers**

Introduction .....	118
Integers .....	122
Addition and Subtraction as Movements .....	124
Adding Integers 1: Counters .....	127
Adding Integers 2 .....	130
Subtracting a Negative Integer .....	133
Add & Subtract Roundup .....	135
Multiplying Integers .....	138
Dividing Integers .....	141
Multiply & Divide Roundup .....	143
Coordinate Grid Practice .....	146
Graphing Linear Functions .....	150
Integers Review .....	154

### **Chapter 9: Probability and Statistics**

Introduction .....	158
Simple Probability .....	163
Probability Problems from Statistics .....	166
Counting the Possibilities .....	168
Compound Probability .....	171
More Practice with Probability .....	175
Data Analysis .....	177
Mean, Median and Mode .....	182
Using Mean, Median and Mode .....	185
Stem-and-Leaf Plots .....	188
Making Histograms .....	190
Range .....	192
Probability and Statistics Review .....	194

(This page intentionally left blank.)

---

## Chapter 6: Percent Introduction

The concept of percent builds on a student's understanding of fractions and decimals. Specifically, students should already be very familiar with the idea of finding a fractional part of a whole (such as finding  $\frac{3}{4}$  of \$240). Students who have used Math Mammoth have been practicing that concept since 4th grade, and one reason why I have emphasized finding a fractional part of a whole so much in the division and fraction materials in the earlier grades is specifically to lay a groundwork for the concept of percent.

Assuming the student has mastered how to find a fractional part a whole, and can easily convert fractions to decimals, studying percent should not be difficult.

The first lesson, *Percent*, practices the concept of percent as  $\frac{1}{100}$ , and how to write fractions and decimals as percentages. The second lesson, *Percentage of a Number*, teaches how to find a certain percentage of a quantity using mental math techniques. For example, students find 10% of \$400 by dividing \$400 by 10. In the next lesson, students find a percentage of a quantity using decimal multiplication, including using a calculator. For example, to find 17% of 45 km, students multiply  $0.17 \times 45$  km.

Then follow lessons about discounts and sales tax, important applications in everyday life. Next we go on to the lesson *Practice with Percent*, which contrasts the two types of problems: questions that ask for a certain percentage of a number (the percentage is given), and questions that ask for the percentage. For example, the first type of question could be “*What is 70% of \$380?*”, and the second type could be “*What percentage is \$70 of \$380?*”

I also present one optional lesson titled *Backwards Questions with Percent*, where students need to figure out “the whole” when a partial amount and a percentage are given. For example: “Three-hundred twenty students, which is 40% of all students, take additional PE. How many students are there in total?”

Then follows one lesson concentrating on a tenth of a percent. Thus far, all of the material has been with whole percents. From this lesson on, we will also use a tenth of a percent (such as 13.4%). We go on to compare ratios, fractions, and percent in one lesson. Next, students study how to make a circle graph.

The last major topic is percent of change. This deals of course with decreases and increases in quantities (such as prices). We also study how to find the percent of change when the original and new amount are known.

Tying in with percent of change, there is one lesson on *Comparisons with Percent*. It ties in, because the way to solve comparisons involving percent (such as how many percent less/more is one thing than another) is identical to finding percent of change.

*Note:* The first few lessons in this chapter are very similar to the percent lessons in Math Mammoth Grade 5-B curriculum. They are similar, but the problems use different numbers. This is on purpose: If your student did study from Math Mammoth Grade 5-B, then these first lessons will be review, hopefully fairly easy. However, if your student didn't study Math Mammoth in 5th grade, then these lessons will provide a foundation for the concept of percent.

## The Lessons in Chapter 6

	page	span
Percent .....	9	4 pages
Percentage of a Number .....	13	3 pages
Percentage of a Number: Using Decimals ....	16	3 pages
Discounts .....	19	2 pages
Sales Tax .....	21	2 pages
Practice with Percent .....	23	3 pages
“Backwards” Questions with Percent .....	26	1 page
Tenth of a Percent .....	27	2 pages
Ratios, Fractions and Percent .....	29	3 pages
Circle Graphs .....	32	2 pages
Percent of Change .....	34	3 pages
Percent of Change, Part 2 .....	37	2 pages
Percent of Change: Applications .....	39	2 pages
Comparisons with Percent .....	41	4 pages
Review Percent .....	45	4 pages

## Helpful Resources on the Internet

### *Games & Tools*

#### **Virtual Manipulative: Percentages**

Interactive tool where you fill in any two of the three 'boxes' (whole, part, and percent) and it will calculate the missing part and show the result visually in two ways.

[http://matti.usu.edu/nlvm/nav/frames\\_asid\\_160\\_g\\_2\\_t\\_1.html](http://matti.usu.edu/nlvm/nav/frames_asid_160_g_2_t_1.html)

#### **Mission: Magnetite**

Hacker tries to drop magnetite on Motherboard. To stop him, match up percentages, fractions, and images showing fractional parts.

<http://pbskids.org/cyberchase/games/percent/percent.html>

#### **Fractions and Percent Matching Game**

A simple matching game: match fractions and percentages.

[http://www.mathplayground.com/matching\\_fraction\\_percent.html](http://www.mathplayground.com/matching_fraction_percent.html)

#### **Fraction/Decimal/Percent Jeopardy**

Answer the questions correctly, changing between fractions, decimals, and percentages.

<http://www.quia.com/cb/34887.html>

(This page intentionally left blank.)

# Percentage of a Number

**100% of something means all of it. 1% of something means 1/100 of it.**

To calculate a percentage of some quantity is like calculating a fractional part of that quantity because *percent* simply means a hundredth part. Therefore, percentages are just fractions.

**How much is 1% of 200 kg?** This means how much is 1/100 of 200 kg? It is simply 2 kg.

**To find 1% of something (1/100 of something), divide by 100.**

Remember how to divide by 100 mentally: Just move the decimal point two places to the left. For example, 1% of 540 is 5.4. And 1% of 8.30 is 0.083.

**To find 2% of some quantity, first find 1% of it, and double that.**

For example, let's find 2% of \$6. Since 1% of 6 is \$0.06, then 2% of 6 is \$0.12.

**To find 10% of some quantity, divide by 10.**

Why does that work? 10% is 10/100. And, 10/100 is equal to 1/10. So we just find 1/10 of a quantity!

For example, 10% of \$780 is \$78. Or, 10% of \$6.50 is \$0.65.

(To divide by 10 mentally, just move the decimal point one place to the left.)

**Can you think of a way to find 20% of a number?** (Hint: Start with finding 10% of the number.)

1. Find 10% of these numbers.

a. 700 \_\_\_\_\_      b. 321 \_\_\_\_\_      c. 60 \_\_\_\_\_      d. 7 \_\_\_\_\_

2. Find 1% of these numbers.

a. 700 \_\_\_\_\_      b. 321 \_\_\_\_\_      c. 60 \_\_\_\_\_      d. 7 \_\_\_\_\_

3. One percent of Mom's paycheck is \$22. How much is her total paycheck?

4. Fill in the table. Use mental math.

percentage / number	1,200	80	29	9	5.7
1% of the number					
2% of the number					
10% of the number					
20% of the number					

5. Fill in this guide for using mental math with percentages:

Mental Math and Percentage of a Number	
50% is $\frac{1}{2}$ . To find 50% of a number, divide by _____.	50% of 244 is _____.
10% is $\frac{1}{10}$ . To find 10% of a number, divide by _____.	10% of 47 is _____.
1% is $\frac{1}{100}$ . To find 1% of a number, divide by _____.	1% of 530 is _____.
To find 20%, 30%, 40%, 60%, 70%, 80%, or 90% of a number, <ul style="list-style-type: none"> <li>• First find _____% of the number and</li> <li>• then multiply by 2, 3, 4, 6, 7, 8, or 9.</li> </ul>	10% of 120 is _____. 30% of 120 is _____. 60% of 120 is _____.

6. Find the percentages. Use mental math.

a. 10% of 60 kg _____ 20% of 60 kg _____	b. 10% of \$14 _____ 30% of \$14 _____	c. 10% of 5 mi _____ 40% of 5 mi _____
d. 1% of \$60 _____ 4% of \$60 _____	e. 10% of 110 cm _____ 70% of 110 cm _____	f. 1% of \$1,330 _____ 3% of \$1,330 _____

7. David pays a 20% income tax on his \$2,100 salary.  
How many dollars is the tax?

How much money does he have left after paying the tax?

8. Nancy pays 30% of her \$3,100 salary in taxes. How much money does she have left after paying the tax?

9. Identify the errors that these children made. Then find the correct answers.

<p>a. Find 90% of \$55.</p> <p>Peter's solution: 10% of \$55 is \$5.50 So subtract 100% - \$5.50 = \$94.50</p>	<p>b. Find 6% of \$1,400.</p> <p>Patricia's solution: 1% of \$1,400 is \$1.40. So, 6% is six times that, or \$8.40.</p>
--	---

(This page intentionally left blank.)

# Discounts

Other than figuring sales tax, the area of life in which you will probably most often need to use percentages is in calculating discounts when you are shopping.

**Example 1.** A laptop that costs \$600 is 20% off. What is the sale price?



Simply put, we calculate 20% of \$600. That is the discounted amount in *dollars*. Then we subtract that from the original price, \$600.

20% of \$600 is \$120. So  $\$600 - \$120 = \$480$ .

**Another way:** Since 20% of the price has been removed, 80% of the price is left. So by calculating 80% of the original price, you will get the new discounted price:







$$0.8 \times \$600 = \$480$$

1. All of these items are on sale. Calculate the discount in dollars and the resulting sale price.

<p><b>a.</b></p>  <p>Price: \$90 20% off</p> <p>Discount amount: \$ <u>18</u> Sale price: \$ _____</p>	<p><b>b.</b></p>  <p>Price: \$5 40% off</p> <p>Discount amount: \$ _____ Sale price: \$ _____</p>	<p><b>c.</b></p>  <p>Price: \$15 30% off</p> <p>Discount amount: \$ _____ Sale price: \$ _____</p>
---	--	---

2. A \$25 swimsuit was on sale for 20% off.  
Monica calculated the discounted price this way:  
 $\$25 - \$20 = \$5$ .  
What went wrong? Find the correct discounted price.

3. All the items are on sale. Find the discounted price.

<p><b>a.</b></p>  <p>Price: \$1.20 25% off</p> <p>Discounted price: \$ _____</p>	<p><b>b.</b></p>  <p>Price: \$18 25% off</p> <p>Discounted price: \$ _____</p>	<p><b>c.</b></p>  <p>Price: \$150 30% off</p> <p>Discounted price: \$ _____</p>
<p><b>d.</b></p>  <p>Price: \$20 40% off</p> <p>Discounted price: \$ _____</p>	<p><b>e.</b></p>  <p>Price: \$2.20 10% off</p> <p>Discounted price: \$ _____</p>	<p><b>f.</b></p>  <p>Price: \$1.30 50% off</p> <p>Discounted price: \$ _____</p>

You can often use **estimation** when calculating the discounted price, especially if you don't have a calculator with you while shopping.

**Example.** A \$198.95 bicycle is discounted by 25%. What is the discounted price?

To estimate it, round the original price of the bicycle to \$200.  
25% of \$200 is  $\frac{1}{4}$  of \$200, or \$50. So the discounted price is \$150.

**Example.** A \$425.90 laptop is discounted by 28%. What is the discounted price?

Round the discount percentage to 30%, and the price of the laptop to \$430.  
10% of \$430 is \$43. 30% of \$430 is three times that much, or \$129. Subtract using rounded numbers:  $\$430 - \$129 = \$300$ .

4. Estimate the discounted price.

a. 30% off of a \$39.90 book   b. 17% off of a \$12.50 block of cheese   c. 75% off of a \$75.50 pair of shoes

5. Which is a better deal? Estimate using rounded numbers and mental math.

a. 75% off of a \$199 brand-name mp3 player  
OR an off-brand mp3 player for \$44.99

b. 40% off of a new, \$89 textbook  
OR a used copy of the same textbook for \$39.90.

6. Which of these methods work for calculating the discounted price for 25% off of \$46?

$0.75 \times \$46$	$\$46 - 0.25 \times \$46$	$\$46 - 0.75 \times \$46$	$3 \times \$46 \div 4$
$0.25 \times \$46$	$\$46 - \frac{\$46}{4}$	$\frac{\$46}{4}$	$\frac{\$46}{4} \times 3$

7. A company sells a computer program for \$39.99. They estimate they could sell 50 copies of it in a week, with that price. But if they discount the price by 25%, they think they could sell 100 copies.

*Estimate* which way would they earn the most money.

8. The original price of a phone was \$60, and the new, discounted price was \$48.  
How many percent was the discount?

(This page intentionally left blank.)



# Percent of Change

**Percent of change** has to do with situations where a price or some other quantity *increases* or *decreases* (changes) by a percentage. First we'll review discounts and price increases. Then we'll study how to calculate the percent of change — that is, how to find how many percent the price or other quantity changed.





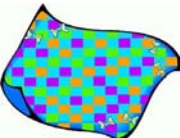

You've already studied discounts, where the price of an item is discounted by 10%, 15%, or some other percentage. Similarly, the price of an item can also *increase* by a certain percentage.

**Example.** An airline ticket costs \$120 now. Next week it goes up by 10%. What will the new price be? First, calculate 10% of \$120. That's \$12. Since the price is going *up*, we *add* that to the current price:  $\$120 + \$12 = \$132$ . So the new price is \$132.

1. Let's review. All these items are on sale. Calculate the new, discounted price.

 <p><b>a.</b> Price: \$9 20% off</p> <p>New price: \$ _____</p>	 <p><b>b.</b> Price: \$6 25% off</p> <p>New price: \$ _____</p>	 <p><b>c.</b> Price: \$90 30% off</p> <p>New price: \$ _____</p>
--	--	---

2. The price of these items goes up. Find the new price.

 <p><b>a.</b> Price: \$5,000 10% increase</p> <p>New price: \$ _____</p>	 <p><b>b.</b> Price: \$110 20% increase</p> <p>New price: \$ _____</p>	 <p><b>c.</b> Price: \$90 30% increase</p> <p>New price: \$ _____</p>
 <p><b>d.</b> Price: \$3 15% increase</p> <p>New price: \$ _____</p>	 <p><b>e.</b> Price: \$2 30% increase</p> <p>New price: \$ _____</p>	 <p><b>f.</b> Price: \$1.50 50% increase</p> <p>New price: \$ _____</p>

3. A jacket costs \$50. First, its price increases by 20%. Then, it is discounted by 20%. Calculate the final price. Notice: it will NOT be \$50!

**Example.** A phone cost \$50 at first. Now it is discounted, and costs \$45.  
How many percent was the discount?

Note: The problem is asking for the *percentage*—not for the new price! It is solved in two steps:

1. We find how much was subtracted from the original price to get the discounted price. This means finding the difference  $\$50 - \$45 = \$5$ . This \$5 is the amount of the discount in dollars.
2. Then we find how many percent this \$5 difference is of the original \$50 price.  
How many percent is \$5 of \$50? It is  $5/50 = 1/10 = 10\%$ .

So the discount was 10%.

4. Fill in the blanks, and calculate how many percent the discount is in each case.

- a.** A toy construction set costs \$12.  
It is discounted and costs only \$8 now.  
How many percent is the discount?
1. First we find out how much was subtracted from \$12 to get \$8 (the DIFFERENCE).  
It is \$ \_\_\_\_\_
  2. Then we find how many percent \$ \_\_\_\_\_ is of the original price, \$12:

- b.** A sewing kit costs \$20. It is discounted and costs only \$16 now. How many percent is the discount?
1. First we find out how much was subtracted from \$ \_\_\_\_\_ to get \$ \_\_\_\_\_ (the DIFFERENCE). It is \$ \_\_\_\_\_
  2. Then we find how many percent \$ \_\_\_\_\_ is of the original price, \$20:

5. A portable reading device costs \$250.  
Now it is discounted and costs \$225.  
How many percent was the discount?

Compare these two problems carefully:

**A shirt costs \$24 at first.  
Now it is discounted by 25%.  
What is the new price?**

1. Calculate 25% of \$24.  
Since  $25\% = 1/4$ , this is  $1/4$  of \$24, or \$6.
2. Subtract  $\$24 - \$6 = \$18$ .  
That is the new price.



**A shirt costs \$24 at first. Now it is discounted, and costs \$18.  
How many percent was the discount?**

1. Find how much was subtracted from \$24 to get \$18 (the difference). That's \$6. So it was discounted by \$6.
2. Find how many percent \$6 is of the original price, \$24. It is  $6/24 = 1/4 = 25\%$ . So the discount was 25%.

When we find the percentage of discount from a discount price (on the right), we work “backwards” compared to when we find the discounted price from a percentage discount (on the left).

## Percent of increase

When the price increases, we can calculate that increase as a percent, too. Compare:

**Gasoline cost \$3/gallon last week.**

**Now it has gone up by 5%.**

**What is the new price?**

1. Calculate 5% of \$3. Since 10% of \$3 is \$0.30, then 5% is half of that, or \$0.15.
2. Add  $\$3 + \$0.15 = \$3.15$ /gallon.  
That is the new price.



**Gasoline cost \$3 last week. Now it costs \$3.15. How many percent was the price increase?**

1. Find how much was added to \$3 to get \$3.15 (the difference). That is \$0.15.
2. Find how many percent \$0.15 is of the original price, \$3. It is  $15/300 = 5/100 = 5\%$ . So, the percent of increase was 5%.

In finding the percent of increase (on the right), we work “backwards” compared to finding the price when the percent of increase is known (on the left).

Notice also that we used *cents* ( $\text{¢}$ ) when calculating what part \$0.15 (15¢) is of \$3 (300¢)!

6. Fill in the missing information. Find the percent of increase.

**a.** A bouquet of flowers used to cost \$15, but now it costs \$20.  
What is the percent of increase?

1. First we find out how much was added to \$15 to get \$20 (the DIFFERENCE). It is \$ \_\_\_\_\_
2. Then we find how many percent \$ \_\_\_\_\_ is of the original price, \$15:

**b.** A chair used to cost \$20, but now it costs \$26.  
What is the percent of increase?

1. First we find out how much was added to \$20 to get \$26 (the DIFFERENCE). It is \$ \_\_\_\_\_
2. Then we find how many percent \$ \_\_\_\_\_ is of the original price, \$20:

7. Fill in the missing information and find the percent of increase or decrease.

**a.** A flashlight used to cost \$9, but now it costs \$8.10.  
What is the discount percent?

1. The difference in price is \$ \_\_\_\_\_
2. Find how many percent that \$ \_\_\_\_\_ is of the original price, \$9:

**b.** A stove used to cost \$160, but now it costs \$200.  
What is the percent of increase?

1. The difference in price is \$ \_\_\_\_\_
2. Find how many percent that \$ \_\_\_\_\_ is of the original price, \$ \_\_\_\_\_:

(This page intentionally left blank.)

---

# Chapter 7: Geometry

## Introduction

The main topics in this chapter include

- angle relationships
- classifying triangles and quadrilaterals
- angle sum of triangles and quadrilaterals
- congruent transformations, including some in the coordinate grid
- similar figures, including using ratios and proportions
- review of the area of all common polygons
- circumference of a circle ( $\pi$ )
- area of a circle
- conversions between units of area (both metric and customary)
- volume and surface area of common solids
- conversions between units of volume (both metric and customary)

This is a lot of topics, and includes a lot of geometry topics taught commonly in middle school, though not all. For example, Pythagorean Theorem, constructions, and the area of a sector of a circle are not covered here. Some topics are not covered to the same depth as you would expect in 7th or 8th grade, such as congruent transformations or angle relationships. After studying this chapter, most students should be fine to study the geometry sections of a typical pre-algebra course (8th grade).

We start out by studying some simple angle relationships such as vertical angles and corresponding angles, and angle problems that involve logical reasoning. Classifying triangles (according to angles and sides) is mostly review, as is the later lesson of classifying quadrilaterals. As new topics, students learn the angle sum of a triangle and any quadrilateral.

After some drawing problems and a simple lesson on similar figures, we study similar figures using a scale ratio. This lesson ties in with proportions and involves mostly calculations.

Next we turn our attention to congruent transformations (translation, rotation, reflection). These are studied also in the coordinate grid, which allows us to exactly describe the location of the original and of the transformed figure.

The next lessons have to do with area. We review the area of triangles, parallelograms, and polygons in two lessons. Then we study new material: the circumference and area of a circle, which both involve using  $\pi$ .

Unit conversions (for area units) are a difficult topic for many. I have tried to take it step-by-step and emphasize the principle in the conversions. And lastly, we study the volume and surface area of solids.

I have striven to make connections between geometry and other areas of mathematics, such as using proportions and ratios with similar figures, including problems that involve the use of percent, coordinate grid, and even equations. Student will also use a calculator in some problems (those are marked with a small calculator symbol). There are still lots of drawing problems, though calculations are becoming more important than in earlier grades.

### The Lessons in Chapter 7

	page	span
Angle Relationships .....	55	4 pages
Classify Triangles .....	59	2 pages
Angles in a Triangle .....	61	2 pages
Quadrilaterals Review .....	63	2 pages
Angles in Polygons .....	65	2 pages
Drawing Problems .....	67	2 pages
Congruent and Similar Figures .....	69	2 pages
Similar Figures and Scale Ratio .....	71	3 pages
Congruent Transformations .....	74	2 pages
Transformations in the Coordinate Grid .....	76	4 pages
Review: Area of Polygons 1 .....	80	3 pages
Review: Area of Polygons 2 .....	83	2 pages
Circumference of a Circle .....	85	3 pages
Area of a Circle .....	88	3 pages
Area and Perimeter Problems .....	91	3 pages
Converting Between Metric Area Units .....	94	4 pages
Converting Between Customary Area Units .....	98	4 pages
Volume of Prisms and Cylinders .....	102	3 pages
Volume of Pyramids and Cones .....	105	3 pages
Surface Area .....	108	3 pages
Converting Between Units of Volume .....	111	2 pages
Geometry Review .....	113	5 pages

(This page intentionally left blank.)

# Angles in Polygons

## The angle sum in a quadrilateral is $360^\circ$ .

See if you can understand and fill in this proof about the angle sum in a quadrilateral!

**PROOF.** Look at the quadrilateral ABCD. We draw a diagonal into it. The diagonal divides the quadrilateral into two triangles, triangle ABC and triangle ACD.

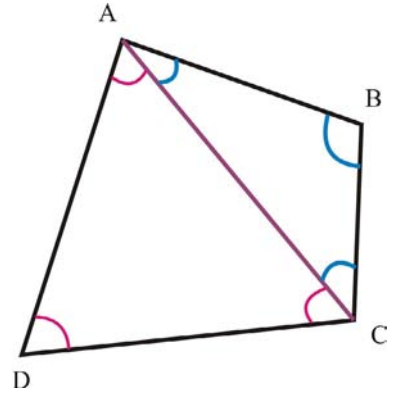

The angle B from triangle ABC is also an angle of the quadrilateral. The angle D from triangle ACD is also an angle of the quadrilateral.

Angle BCA and angle ACD are angles in the two triangles (the two angles with vertex C), but they also form together one angle of the quadrilateral. Similarly, angle CAB and angle DAC are angles in the two triangles (the two marked angles with vertex A), but they also form together another angle of the quadrilateral.

The angle sum of triangle ADC is \_\_\_\_\_ degrees, and the angle sum of triangle ABC is also \_\_\_\_\_ degrees,

It follows that the four angles in the quadrilaterals ABCD are formed of the angles of the two triangles. Thus, the angle sum of a quadrilateral is twice \_\_\_\_\_ $^\circ$ , or \_\_\_\_\_ $^\circ$ .

- The figure illustrates how we can find the angle sum in a pentagon. Use the reasoning above to find the angle sum of a pentagon.

The angle sum of a pentagon is \_\_\_\_\_ $^\circ$ .

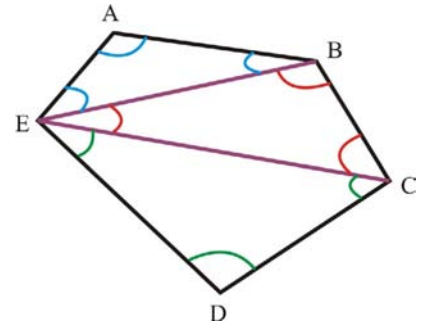

- Draw six points randomly. Connect them with a ruler so you get a hexagon. Then, divide it into triangles using diagonals. Use the reasoning above to find the angle sum of a hexagon.

It is \_\_\_\_\_ $^\circ$ .

3. You have seen this picture earlier. It has two sets of parallel lines. We see lots of *vertical angles* and *corresponding angles*.

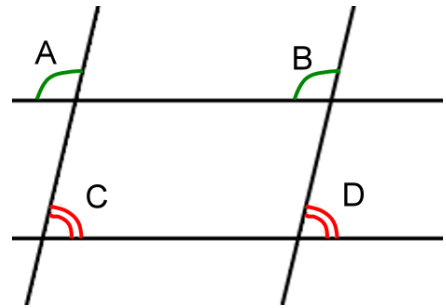

a. Angle A is  $102^\circ$ . Mark in the picture (using a single arc) all the other angles that are also  $102^\circ$ .

b. Mark in the picture (using a double arc) all the other angles that measure the same as angle C.

c. How many degrees is angle C? \_\_\_\_\_ $^\circ$

d. What quadrilateral is enclosed by the two sets of parallel lines? \_\_\_\_\_

From this figure we can learn something special about the angles in a parallelogram:

**In a parallelogram, the opposite angles are congruent.**

Also, two "neighboring" angles have the angle sum of 180 degrees.

In total, the four angles of course add up to  $360^\circ$ , just like in any quadrilateral.

4. One angle in a parallelogram is  $74^\circ$ . What are the measures of its other angles?

\_\_\_\_\_ $^\circ$ , \_\_\_\_\_ $^\circ$  and \_\_\_\_\_ $^\circ$ .

Now draw one such parallelogram.

You can choose the side lengths.

5. One angle of a rhombus is  $115^\circ$ . What are the measures of its other angles?

\_\_\_\_\_ $^\circ$ , \_\_\_\_\_ $^\circ$  and \_\_\_\_\_ $^\circ$ .

Now draw one such rhombus. You can choose the side length. Just remember, in a rhombus, all sides are congruent.

### Puzzle Corner

a. This is a regular pentagon. The angle marked with "?" is called an *exterior angle* of the pentagon. Figure out its angle measure.

b. This is a regular hexagon. Figure out the measure of the exterior angle (marked with "?").

c. How many degrees is the exterior angle of a regular nonagon?

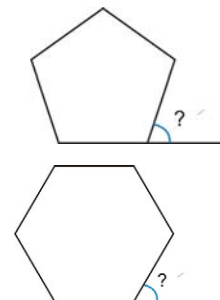

(This page intentionally left blank.)

# Review: Area of Polygons 1

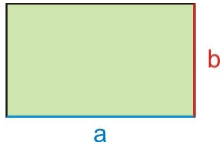
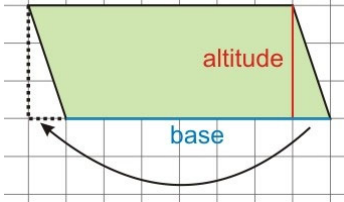
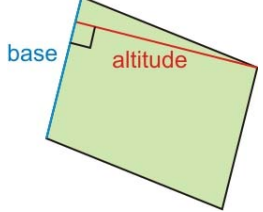
<p><b>1. Area of rectangle</b></p>  <p style="text-align: center;"><math>A = ab</math></p> <p>The area is <i>side</i> <math>\times</math> <i>side</i>. We can denote the side lengths with <i>a</i> and <i>b</i> or with other letters.</p> <ul style="list-style-type: none"> <li>Remember to use square units for the area! If you measure the sides in millimeters, the area will be in square millimeters.</li> </ul>	<p><b>2. Area of parallelogram</b></p>  <p style="text-align: center;"><math>A = bh</math></p> <p>Any parallelogram can be transformed into a rectangle (see illustration) with the same area. That is why the area is <i>base</i> <math>\times</math> <i>altitude</i>. The letter <i>b</i> stands for base, and <i>h</i> for height/altitude.</p> <p>Here, <i>b</i> is 3 units, <i>h</i> is 7 units, and the area = 21 square units.</p>	 <p>The altitude is always <u>perpendicular</u> to the base, and is drawn from between the base and the opposite side.</p> <p>Any side of the parallelogram can be chosen to be the base.</p>
--	--	--

- The area of Reynolds's rectangular plot is 750 m<sup>2</sup>. If one side is 30 m, what is the other side?
- The area of a rectangular stamp is 6.6 cm<sup>2</sup>. If one side is 22 mm, what is the other side?
- Measure what you need, and calculate the area of the parallelograms in square centimeters, rounding to the nearest square centimeter.

Use a protractor to draw the altitude so it is perpendicular to the base.

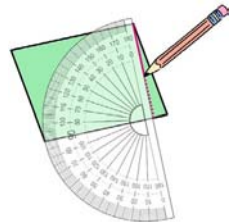
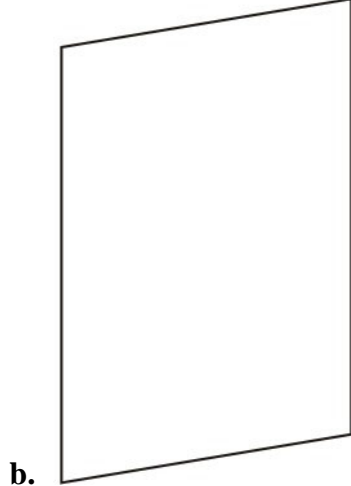
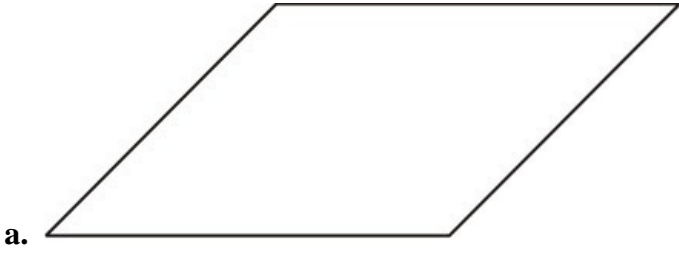

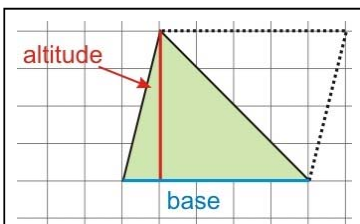
$$A = \frac{1}{2}bh$$

$b$  is 5 units,  $h$  is 4 units,  
 $A = 10$  square units

### 3. Area of triangle

Any triangle is exactly half of a certain parallelogram. The triangle and parallelogram share the same base and the same altitude. Therefore, the area of a triangle is half of the area of the corresponding parallelogram.

The altitude of the triangle is perpendicular to the base, and is drawn from the vertex that is opposite of the base.

The letter  $b$  stands for base, and  $h$  stands for height/altitude.

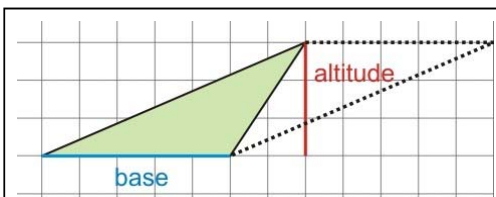

$b$  is 5 units,  $h$  is 3 units,  
 $A = 7.5$  square units

Sometimes the altitude of a triangle falls outside the triangle itself. It still needs to be drawn from the vertex, and perpendicular to the base.

Again, you can choose which side of the triangle is the base. So, all triangles have three different altitude & base pairs.

For *right triangles*, it is often easiest to use the two sides that are perpendicular to each other as the base and the altitude.

4. Draw an altitude to the triangles. Measure what you need, and calculate the area in square centimeters. Round to the nearest square centimeter.

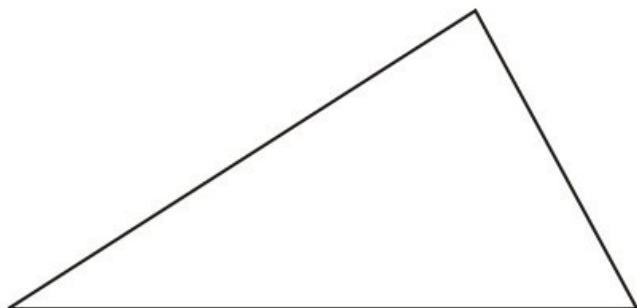

Use a protractor to draw the altitude so it is perpendicular to the base.

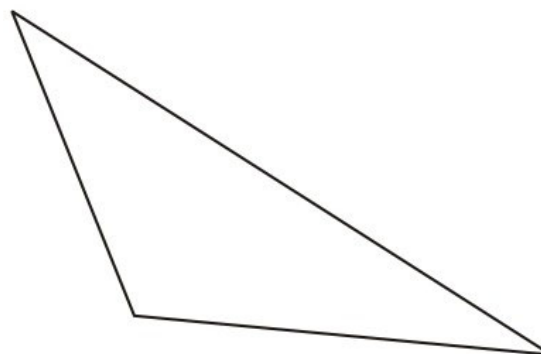
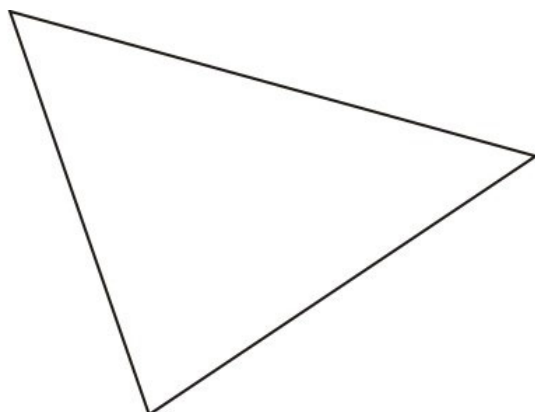
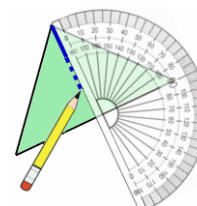

(This page intentionally left blank.)

# Surface Area

**Surface area** of a solid means the total area of all of its faces.

So, to calculate the surface area, simply find the area of each face, and add those.

Sometimes the **net** of a solid helps us with that. The net shows all the faces of the solid drawn in a plane—as if on a flat paper—and you can build the solid from the net by folding.

The net of a circular right cone always has a circle as a base. Then, it has a partially drawn circle (sector of a circle) that is the **lateral** face, or the face that “wraps around” the base.

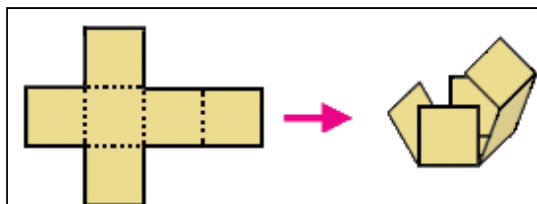

The net of a cube, and it being folded into a cube.

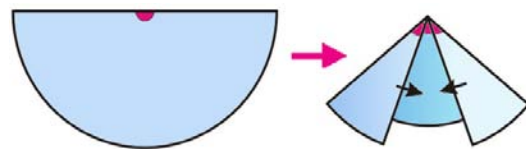

Folding the lateral face of the cone.

**Example 1.** Find the surface area of the cone with this net.

1. The bottom face is a circle with a radius of 2.25 cm. Its area is  $\pi \times (2.25 \text{ cm})^2 \approx 15.89625 \text{ cm}^2$ .
2. The lateral face is a half circle, with a radius of 4.5 cm. Its area is  $0.5 \times \pi \times (4.5 \text{ cm})^2 \approx 31.7925 \text{ cm}^2$ .

Lastly we add the two:  $15.89625 \text{ cm}^2 + 31.7925 \text{ cm}^2 = 47.68875 \text{ cm}^2 \approx 48 \text{ cm}^2$ .

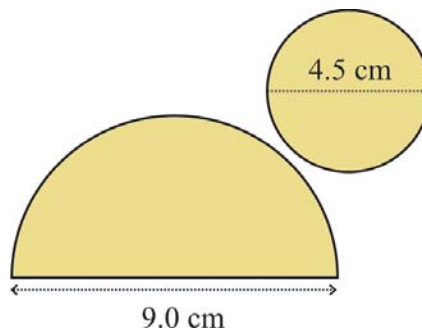

Notice we kept many more decimals for the intermediate results than for our final answer. Don't round your intermediate results very much—do the rounding to the final accuracy only on the final answer.

**Example 2.** Calculate the surface area of this rectangular prism.

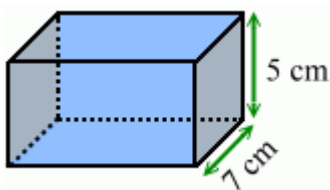

The two faces on the ends are congruent (identical). Each of them has an area of  $7 \text{ cm} \times 5 \text{ cm} = 35 \text{ cm}^2$ .

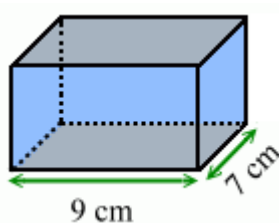

The two faces on the top and bottom are congruent. Each has an area of  $9 \text{ cm} \times 7 \text{ cm} = 63 \text{ cm}^2$ .

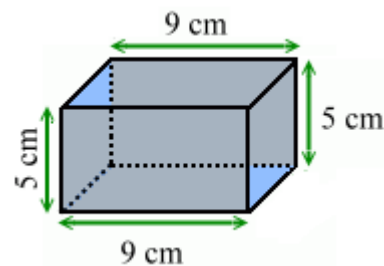

The two faces on the front and back are also congruent. Each has an area of  $9 \text{ cm} \times 5 \text{ cm} = 45 \text{ cm}^2$ .

So the total surface area is:

$$2 \times 35 \text{ cm}^2 + 2 \times 63 \text{ cm}^2 + 2 \times 45 \text{ cm}^2 = 70 \text{ cm}^2 + 126 \text{ cm}^2 + 90 \text{ cm}^2 = 286 \text{ cm}^2.$$



1. Find the surface area of these water tanks.

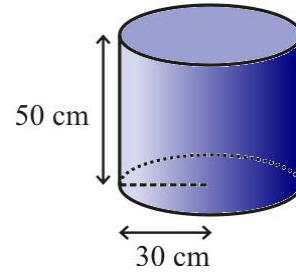
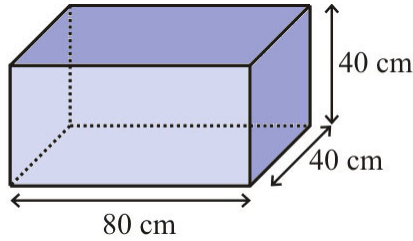
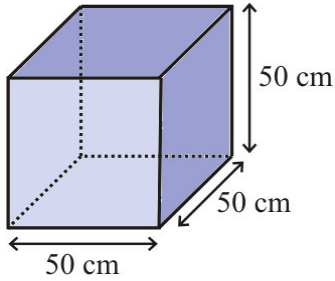

a. \_\_\_\_\_  $\text{cm}^2$       b. \_\_\_\_\_  $\text{cm}^2$       c. \_\_\_\_\_  $\text{cm}^2$

2. Note that  $1 \text{ m}^2 = (100 \text{ cm} \times 100 \text{ cm}) = 10,000 \text{ cm}^2$ . Use that to convert the surface areas of the water tanks into square meters.

a. \_\_\_\_\_  $\text{m}^2$       b. \_\_\_\_\_  $\text{m}^2$       c. \_\_\_\_\_  $\text{m}^2$

3. Find the volume of the water tanks in exercise #1.

a. \_\_\_\_\_  $\text{cm}^3$       b. \_\_\_\_\_  $\text{cm}^3$       c. \_\_\_\_\_  $\text{cm}^3$

4. We know that  $1,000 \text{ cm}^3 = 1,000 \text{ ml} = 1 \text{ liter}$ . Use that to convert the volumes of the water tanks into liters.

a. \_\_\_\_\_ l      b. \_\_\_\_\_ l      c. \_\_\_\_\_ l

5. Name the solids that can be built from these nets, and calculate their surface area.

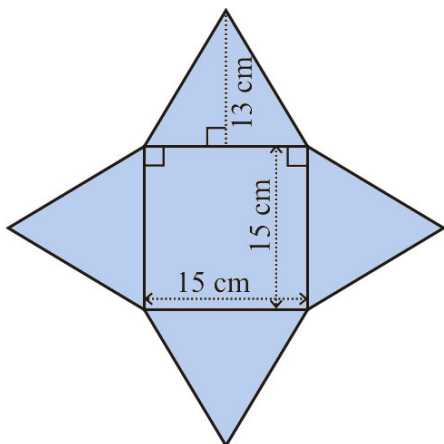

a.  
solid: \_\_\_\_\_  
surface area: \_\_\_\_\_

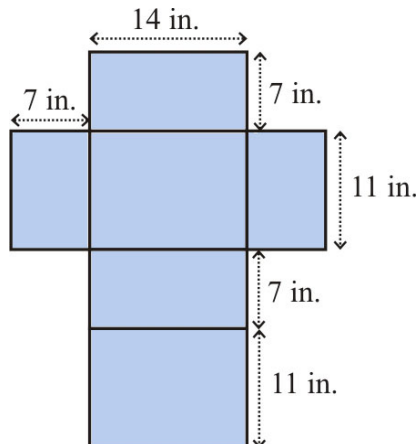

b.  
solid: \_\_\_\_\_  
surface area: \_\_\_\_\_

6. Find the surface areas.

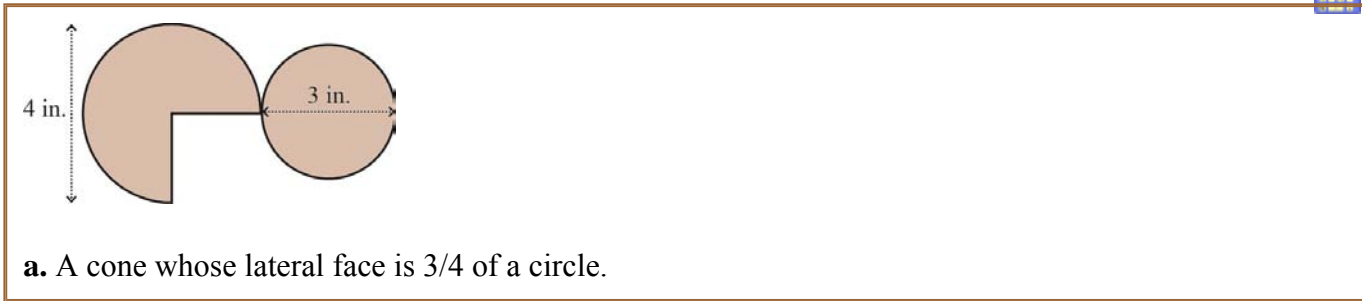

a. A cone whose lateral face is  $\frac{3}{4}$  of a circle.



b. A triangular prism

7. A swimming pool is in the shape of a rectangular prism. It is 12.5 m long, 6 m wide, and 2 m deep.



a. Find the surface area of the pool's bottom and sides (not including the top, since it is not covered).

b. Tile costs \$9.90 per square meter. Calculate the cost of tiling the pool.

8. A gift box is in a shape of a cube with 20-cm sides. Calculate its surface area.

9. One cube has a side of 1 unit, and another cube has a side of 2 units. This means that their sides are in the ratio of 1:2.

a. In what ratio are their surface areas?

b. In what ratio are their volumes?

**Puzzle Corner**

The surface area of a cube is  $150 \text{ cm}^2$ . Calculate the volume of the cube.

(This page intentionally left blank.)

---

# Chapter 8: Integers

## Introduction

Chapter 8 covers all important integer topics in middle school math.

The first topic is integers themselves, presented on a number line and tied in with temperature. Next we move on to modeling additions and subtractions as movements on a number line. Another model used for addition is that of counters or chips. One lesson explains the shortcut for subtracting a negative integer using three different viewpoints (difference, counters, and number line movements). There is also a roundup lesson for addition and subtraction of integers.

Multiplication and division of integers is explained using counters, first of all, and then relying on the properties of multiplication and division. We use multiplication and division in the context of enlarging or shrinking geometric figures in the coordinate grid.

These lessons also include a few simple equations, problems with several operations, and fun riddles.

The last section of lessons in this chapter deals with the coordinate grid. Students move geometric figures up, down, to the right, and left. They reflect figures in the  $x$ -axis and in the  $y$ -axis. Lastly, students graph simple linear functions, first using a range of integer values only, and then without such limitation.

*Note:* The first few lessons in this chapter are very similar to the integer lessons in Math Mammoth Grade 5-B curriculum. They are similar, but the problems use different numbers. This is on purpose: If your student did study from Math Mammoth Grade 5-B, then these first lessons will be review, hopefully fairly easy. However, if your student didn't study Math Mammoth in 5th grade, then these lessons will provide a foundation for the concept of integers.

### The Lessons in Chapter 8

	<b>page</b>	<b>span</b>
Integers .....	122	2 pages
Addition and Subtraction as Movements .....	124	3 pages
Adding Integers 1: Counters .....	127	3 pages
Adding Integers 2 .....	130	3 pages
Subtracting a Negative Integer .....	133	2 pages
Add & Subtract Roundup .....	135	3 pages
Multiplying Integers .....	138	3 pages
Dividing Integers .....	141	2 pages
Multiply & Divide Roundup .....	143	3 pages
Coordinate Grid Practice .....	146	4 pages
Graphing Linear Functions .....	150	4 pages
Integers Review .....	154	4 pages

(This page intentionally left blank.)

## Adding Integers 1: Counters

Addition of integers can be modeled using counters.

We'll use red counters with a "+" sign for positives and blue counters with a "-" sign for negatives.

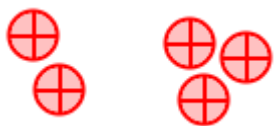

This picture shows the addition,  $2 + 3$ . There is one group of 2 positives and another group of 3 positives. The sum is simply 5.

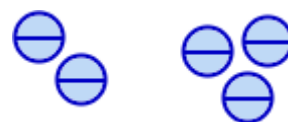

This picture shows the addition,  $(-2) + (-3)$ . We *add* negatives and negatives. In total there are five negatives, so the sum is  $-5$ .

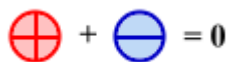

$$1 + (-1) = 0$$

One positive counter and one negative counter *cancel* each other. In other words, their sum is zero!



$$2 + (-2) = 0$$

Two negatives and two positives also cancel each other. Their sum is zero.



$$3 + (-1) = 2$$

Here, one "positive-negative" pair is canceled, and we are left with 2 positives.



$$(-4) + 3 = -1$$

Now the negatives outweigh the positives. Pair up three of each, and there is still one negative left.

1. Refer to the pictures and add. Remember each "positive-negative" pair is canceled.

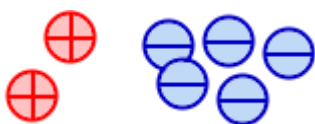

a.  $2 + (-5) = \underline{\hspace{2cm}}$

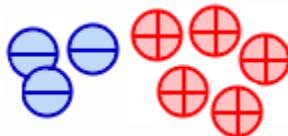

b.  $(-3) + 5 = \underline{\hspace{2cm}}$



c.  $(-6) + (-3) = \underline{\hspace{2cm}}$

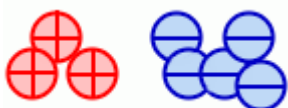

d.  $3 + (-5) = \underline{\hspace{2cm}}$

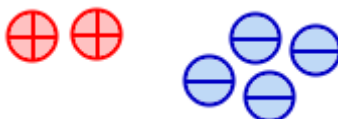



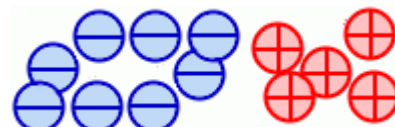

e.  $2 + (-4) = \underline{\hspace{2cm}}$

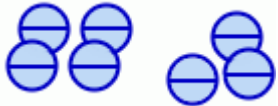
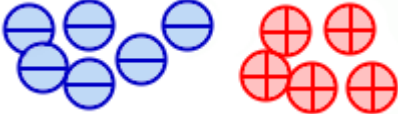

f.  $(-8) + 5 = \underline{\hspace{2cm}}$

2. Write addition sentences (equations) to match the pictures.

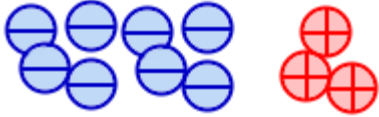
<p>a. </p>	<p>b. </p>	<p>c. </p>
<p>d. </p>	<p>e. </p>	<p>f. </p>

3. Rewrite these sentences using symbols, and solve the resulting addition problems.

- The sum of seven positives and five negatives.
- Add  $-3$  and  $-11$ .
- Positive 100 and negative 15 added together.

**A note on notation**

We can write an elevated minus sign to indicate a negative number:  $\bar{4}$ .

Or we can write it with a minus sign and parentheses:  $(-4)$ .

We can even write it without the parentheses if the meaning is clear:  $-4$ .

So  $\bar{4} + \bar{4} = \bar{8}$  is the same as  $(-4) + (-4) = (-8)$ , which is the same as  $-4 + (-4) = -8$

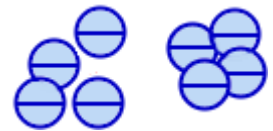

You *should* write the parentheses if you have  $+$  and  $-$ , or two  $-$  signs, next to each other. So don't write " $8 + - 4$ "; write " $8 + (-4)$ ." And don't write " $3 - -3$ "; write " $3 - (-3)$ ."

4. Think of the counters. Add.

<p>a. <math>7 + (-8) =</math> <math>(-7) + 8 =</math></p>	<p>b. <math>(-7) + (-8) =</math> <math>7 + 8 =</math></p>	<p>c. <math>5 + (-7) =</math> <math>7 + (-5) =</math></p>	<p>d. <math>50 + (-20) =</math> <math>10 + (-40) =</math></p>
<p>e. <math>\bar{2} + \bar{4} =</math> <math>\bar{6} + 6 =</math></p>	<p>f. <math>10 + \bar{1} =</math> <math>\bar{10} + \bar{1} =</math></p>	<p>g. <math>\bar{8} + 2 =</math> <math>\bar{8} + \bar{2} =</math></p>	<p>h. <math>\bar{9} + \bar{1} =</math> <math>9 + \bar{1} =</math></p>

5. Find the number that is missing from the equations.

<p>a. <math>(-3) + \underline{\quad} = (-7)</math></p>	<p>b. <math>(-3) + \underline{\quad} = 3</math></p>	<p>c. <math>3 + \underline{\quad} = (-7)</math></p>
--	---	---

(This page intentionally left blank.)

# Dividing Integers

## Divide a negative number by a positive

The image illustrates  $(-8) \div 4$ , or eight negatives divided into four groups. We can see the answer is  $-2$ .

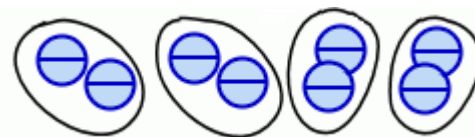

Any time a negative integer is divided by a positive integer, we can illustrate it as so many negative counters divided into groups. The answer will be negative.

So each time you divide a negative integer by a positive integer, the answer is negative.

## Divide a positive integer by a negative. For example, $24 \div (-8) = ?$

Remember multiplication is the opposite operation of division. Let's write the answer of  $24 \div (-8)$  as  $s$ . Then we write a multiplication equation using the division:

$$24 \div (-8) = s \quad \Rightarrow \quad (-8)s = 24$$

(You could use an empty line instead of  $s$ , if the variable  $s$  confuses you.)

The only number that fulfills the equation  $(-8)s = 24$  is  $s = -3$ . Therefore,  $24 \div (-8) = -3$ .

Similarly, each time you divide a positive integer by a negative integer, the answer is negative.

## Divide a negative integer by a negative. For example, $(-24) \div (-8) = ?$

Again, let's mark the answer to  $-24 \div (-8)$  with  $y$ , and then write a multiplication sentence.

$$-24 \div (-8) = y \quad \Rightarrow \quad (-8)y = -24$$

The only number that fulfills the equation  $(-8)y = -24$  is  $y = 3$ . Therefore,  $-24 \div (-8) = 3$ .

Similarly, each time you divide a negative integer by a negative integer, the answer is positive.

**Summary.** The symbols below show whether you get a positive or negative answer, when you multiply or divide integers. Notice that the rules for multiplication and division are the same!

Multiplication	Examples	Division	Examples
$\oplus \times \ominus = \ominus$	$4 \times (-5) = -20$	$\oplus \div \ominus = \ominus$	$20 \div (-5) = -4$
$\ominus \times \oplus = \ominus$	$-4 \times 5 = -20$	$\ominus \div \oplus = \ominus$	$-20 \div 5 = -4$
$\ominus \times \ominus = \oplus$	$-4 \times (-5) = 20$	$\ominus \div \ominus = \oplus$	$-20 \div (-5) = 4$
$\oplus \times \oplus = \oplus$	$4 \times 5 = 20$	$\oplus \div \oplus = \oplus$	$20 \div 5 = 4$

Here's a shortcut for multiplication and division (NOT addition or subtraction):

- If both numbers have the same sign (both are positive *or* negative), the answer is positive.
- Otherwise, the answer is negative.

1. Divide.

<b>a.</b> $-50 \div (-5) = \underline{\hspace{2cm}}$ $-12 \div 2 = \underline{\hspace{2cm}}$	<b>b.</b> $(-8) \div (-1) = \underline{\hspace{2cm}}$ $14 \div (-2) = \underline{\hspace{2cm}}$	<b>c.</b> $81 \div (-9) = \underline{\hspace{2cm}}$ $-100 \div (-10) = \underline{\hspace{2cm}}$
---	--	---

2. Multiply. Then write a division equation for each multiplication, using the same numbers.

<b>a.</b> $-5 \times (-5) = \underline{\hspace{2cm}}$ $\underline{\hspace{2cm}} \div \underline{\hspace{2cm}} = \underline{\hspace{2cm}}$	<b>b.</b> $9 \times (-6) = \underline{\hspace{2cm}}$ $\underline{\hspace{2cm}} \div \underline{\hspace{2cm}} = \underline{\hspace{2cm}}$	<b>c.</b> $-80 \times 8 = \underline{\hspace{2cm}}$ $\underline{\hspace{2cm}} \div \underline{\hspace{2cm}} = \underline{\hspace{2cm}}$
--	---	--

3. Complete the patterns.

<b>a.</b>	<b>b.</b>	<b>c.</b>
$12 \div 4 = \underline{\hspace{2cm}}$	$\underline{\hspace{2cm}} \div (-7) = -3$	$60 \div \underline{\hspace{2cm}} = 2$
$8 \div 4 = \underline{\hspace{2cm}}$	$\underline{\hspace{2cm}} \div (-7) = -2$	$40 \div \underline{\hspace{2cm}} = 2$
$4 \div 4 = \underline{\hspace{2cm}}$	$\underline{\hspace{2cm}} \div (-7) = -1$	$20 \div \underline{\hspace{2cm}} = 2$
$0 \div 4 = \underline{\hspace{2cm}}$	$\underline{\hspace{2cm}} \div (-7) = 0$	$-20 \div \underline{\hspace{2cm}} = 2$
$(-4) \div 4 = \underline{\hspace{2cm}}$	$\underline{\hspace{2cm}} \div (-7) = 1$	$-40 \div \underline{\hspace{2cm}} = 2$
$(-8) \div 4 = \underline{\hspace{2cm}}$	$\underline{\hspace{2cm}} \div (-7) = 2$	$-60 \div \underline{\hspace{2cm}} = 2$
$(-12) \div 4 = \underline{\hspace{2cm}}$	$\underline{\hspace{2cm}} \div (-7) = 3$	$-80 \div \underline{\hspace{2cm}} = 2$
$(-16) \div 4 = \underline{\hspace{2cm}}$	$\underline{\hspace{2cm}} \div (-7) = 4$	$-100 \div \underline{\hspace{2cm}} = 2$

4. Here's a funny riddle. Solve the math problems to uncover the answer.

**E**  $\underline{\hspace{2cm}} \div (-8) = 2$

**N**  $-12 \times (-5) = \underline{\hspace{2cm}}$

**E**  $(-144) \div 12 = \underline{\hspace{2cm}}$

**E**  $3 \times (-12) = \underline{\hspace{2cm}}$

**H**  $\underline{\hspace{2cm}} \div 12 = 5$

**T**  $-4 \times (-9) = \underline{\hspace{2cm}}$

**N**  $-15 \div \underline{\hspace{2cm}} = -5$

**E**  $\underline{\hspace{2cm}} \times (-6) = 0$

**V**  $-45 \div \underline{\hspace{2cm}} = 5$

**G**  $-1 \times (-9) = \underline{\hspace{2cm}}$

**I**  $-27 \div 9 = \underline{\hspace{2cm}}$

**I**  $-7 \times \underline{\hspace{2cm}} = -84$

**S**  $-48 \div 6 = \underline{\hspace{2cm}}$

**N**  $3 \times \underline{\hspace{2cm}} = -24$

Why is six afraid of seven? Because....

-8   -12   -9   -36   60

0   12   9   60   36

3   -3   -8   -16

(This page intentionally left blank.)

---

# Chapter 9: Probability and Statistics

## Introduction

In this chapter, probability is a totally new topic that we are tackling. In the past, probability was only taught in high school—for example, I personally encountered it for the first time in 12th grade. However, in recent years it has “crept” down the grade levels and many states require probability topics even in elementary school.

While the concepts we study here are not difficult, I have not felt any need for students to study probability in earlier grades. That way there is more time to focus on the more important topics in grades 1-5. But since probability IS so strongly present in state standards, these lessons allow students following Math Mammoth to learn the main ideas, for this level.

We start with the concept of simple (classic) probability, and then expand into probability involving two events. This is all that is needful to master at this point. The exercises involve tree diagrams, dice, flipping coins, picking marbles, spinning spinners, and probability involving statistics, which are the usual types of situations in the study of probability.

The last lessons then deal with statistical topics. We start out with a lesson on data analysis, which presents various types of graphs for students to read, and reviews some percent-related topics. We go on to mean, median, and mode—the three measures of central tendency— and a little bit on how to use them.

Students also learn how to make stem-and-leaf plots and histograms. Stem-and-leaf plots are simple plots that can be used with 15-100 data items. They are not often seen in media because you cannot use them with large amounts of data. Histograms, on the other hand, are very common graphs. They are just like bar graphs, just with the bars next to each other.

I decided to omit the topic of making box-and-whiskers plots (boxplots) though that is listed in some standards and is covered in some math curricula, because interpreting and using them is really beyond the knowledge of 6th graders. They are not common either.

Lastly, we study range as a simple measure of variance. There exist far better measures of variance, such as the interquartile range, standard deviation, and others, but I feel those are also advanced for 6th grade. Statistical measures is a vast area of study, and I feel it is not necessary to introduce to students all kinds of measures (such as interquartile range) if all that students could do with it is to calculate it, and not use it in a meaningful way in interpreting data. Interpreting data using statistical measures (such as mean, median, mode, standard deviation, and others) is a skill that requires more in-depth understanding of statistics than what can be covered here.

## The Lessons in Chapter 9

	page	span
Simple Probability .....	163	3 pages
Probability Problems from Statistics .....	166	2 pages
Counting the Possibilities .....	168	3 pages
Compound Probability .....	171	4 pages
More Practice with Probability .....	175	2 pages
Data Analysis .....	177	5 pages
Mean, Median and Mode .....	182	3 pages
Using Mean, Median and Mode .....	185	3 pages
Stem-Lead-Plots .....	188	2 pages
Making Histograms .....	190	2 pages
Range .....	192	2 pages
Probability and Statistics Review .....	194	3 pages

## Helpful Resources on the Internet

*Mean, Median, Mode, Range, etc.*

### Using and Handling Data

Simple explanations for finding mean, median, or mode.

<http://www.mathsisfun.com/data/index.html#stats>

### Math Goodies Interactive Statistics Lessons

Clear lessons with examples and interactive quiz questions.

<http://www.mathgoodies.com/lessons/vol8/range.html>

<http://www.mathgoodies.com/lessons/vol8/mean.html>

<http://www.mathgoodies.com/lessons/vol8/median.html>

<http://www.mathgoodies.com/lessons/vol8/mode.html>

### Mean, Median, and Mode

Lesson on how to calculate mean, median, and mode for set of data given in different ways. Also has interactive exercises.

[www.cimt.plymouth.ac.uk/projects/mepres/book8/bk8i5/bk8\\_5i2.htm](http://www.cimt.plymouth.ac.uk/projects/mepres/book8/bk8i5/bk8_5i2.htm)

### GCSE Bitesize Mean, mode and median lessons

Explanations with simple examples.

[www.bbc.co.uk/schools/gcsebitesize/maths/data/measuresofaveragerev1.shtml](http://www.bbc.co.uk/schools/gcsebitesize/maths/data/measuresofaveragerev1.shtml)

(This page intentionally left blank.)

# Compound Probability

Compound probability means finding the probability where two events both occur. If the outcome of the one event does not affect the outcome of the other, they are said to be **independent**. In that case you can find the probability of two events occurring by multiplying the probabilities of the two events. Examples will make this clear.

**Example 1.** You toss a coin, and then you roll a die. What is the probability of getting 6 and heads?

P(6) is  $\frac{1}{6}$ , and P(heads) is  $\frac{1}{2}$ . Clearly, whether you get heads or tails on the coin does not affect what you get on the roll. The two events are *independent*. Therefore, we can multiply the two probabilities.

$$P(6 \text{ and heads}) = \frac{1}{6} \times \frac{1}{2} = \frac{1}{12}$$

You can also see this probability by looking at the tree diagram, because in only one outcome out of the twelve possible ones do we have 6 and heads.

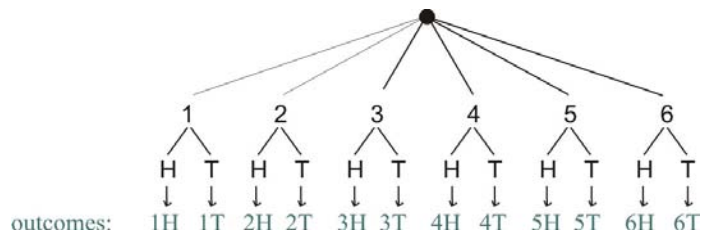

**Example 2.** You toss a coin three times. What is the probability of getting heads every time?

These three events—toss a coin, toss a coin, toss a coin—are independent. Getting heads on one toss doesn't affect whether you get heads or tails on the next.

$$P(\text{heads}) = \frac{1}{2}. \text{ Therefore, } P(\text{heads and heads and heads}) = \frac{1}{2} \times \frac{1}{2} \times \frac{1}{2} = \frac{1}{8}$$

You can also see this from the tree diagram. There is only one outcome with “HHH”, and a total of 8 possible outcomes.

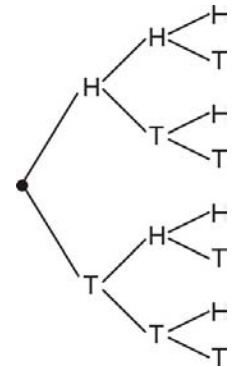

**Example 3.** The bag has three red marbles, two dark blue marbles, and five light green marbles. You take one marble, and put it back. Then you take a marble again, and put it back. What is the probability of getting first a red marble, then a blue one?

Again, we simply multiply the individual probabilities:

$$P(\text{red, blue}) = \frac{3}{10} \times \frac{2}{10} = \frac{6}{100} = \frac{3}{50}$$

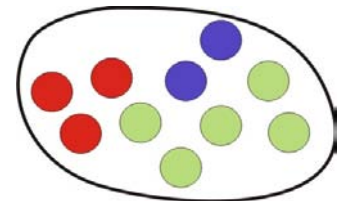

1. You toss a coin three times.
  - a. What is the probability of getting tails, then heads, then tails?
  - b. What is the probability that you get heads on your second toss?
  - c. Use the tree diagram. What is the probability of getting two heads and one tails in three tosses? Note they can be in any order, such as THH or HTH.

2. You take a marble out of the bag and put it back. Then you take another marble. Find the probabilities.

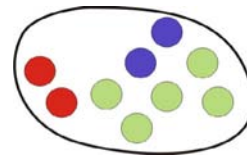

- a.  $P(\text{red, then green})$
- b.  $P(\text{green, then red})$
- c.  $P(\text{not blue, not blue})$
- d.  $P(\text{not red, not red})$

3. You roll a six-sided die two times. Find the probabilities.

- a.  $P(1; 5)$
- b.  $P(\text{even; odd})$
- c.  $P(2; 5 \text{ or } 6)$
- d.  $P(6; \text{not } 6)$

4. The spinner is spun two times. Find the probabilities.

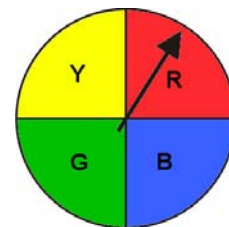

- a.  $P(\text{blue; blue})$
- b.  $P(\text{green; not green})$
- c.  $P(\text{not blue; yellow})$
- d.  $P(\text{yellow or green; red or blue})$

5. The weatherman says that the chance of rain is 20% for each of the next five days, and your birthday is in two days! You also know that the probability of your dad taking you to the amusement park on your birthday is  $1/2$ .

- a. What is the probability that you get to go the park, and it doesn't rain?
- b. What is the probability that you get to go the park, and it rains?

Check: The sum of the probabilities in (a) and (b) should be  $1/2$ .

6. The two spinners are spun. The first spinner has eight regions and the second spinner has four. Find the probabilities:

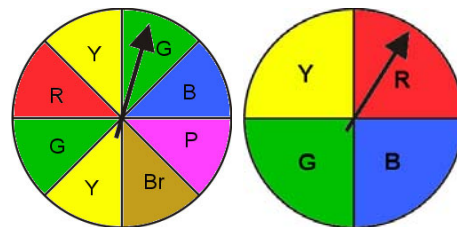

- a.  $P(\text{red, red})$
- b.  $P(\text{blue, not blue})$
- c.  $P(\text{yellow or green, yellow or green})$
- d.  $P(\text{not red, red})$

### Taking an object without replacing it

Let's say you choose a marble and don't put it back. Then you choose another marble. This means you have in effect chosen two marbles. What is the probability that both are red?

We first find the probability that the first marble is red. That is simply  $\frac{3}{10}$  since there are two red marbles and ten in all.

After you get a red marble, and don't put it back, the bag now has one red marble less. So, the probability of getting a red marble now is  $\frac{2}{9}$ .

Thus, the probability of getting two red marbles is  $\frac{3}{10} \times \frac{2}{9} = \frac{1}{15}$ .

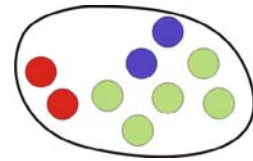
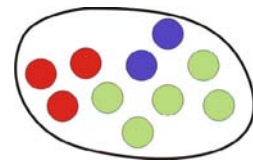

**Example.** You choose one card, without putting it back. Then you choose another. What is the probability that the first is an even number, and the second is 7?

There are four cards with an even number, and eight total cards. So,  $P(\text{even}) = \frac{4}{8} = \frac{1}{2}$ .

After one card with an even number has been drawn, there are seven cards left, and one of them has number 7. So,  $P(7)$  is  $\frac{1}{7}$ .

$P(\text{even}, 7) = \frac{1}{2} \times \frac{1}{7} = \frac{1}{14}$ .



7. You choose a card randomly from this group of cards. Then you choose another card, without replacing the first. Find the probabilities.

a.  $P(\text{heart, heart})$

b.  $P(\text{star, cross})$

c.  $P(\text{not heart, not heart})$

d.  $P(\text{star, not star})$

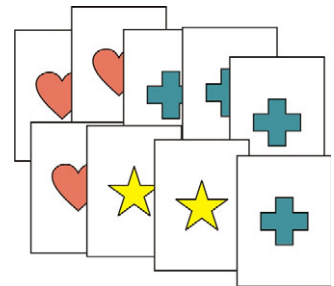

8. You choose two marbles randomly from the bag, without replacement.

a. What is the probability that both are green?

b. What is the probability that the first is green, and the second is red?

c. What is the probability that the first is red, and the second is green?

d. Add the probabilities from (b) and (c) to get the probability that you get one red and one green marble when drawing two marbles.

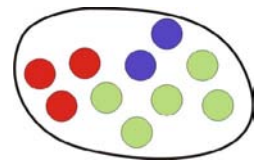

9. You choose one card, without putting it back. Then you choose another. Find the probabilities. Give your answers as fractions and percents.

3	4	5	6
7	8	9	10

- a.  $P(5; 6)$
- b.  $P(\text{not } 5; \text{not } 5)$
- c.  $P(9; \text{even})$
- d.  $P(8 \text{ or } 9; \text{not } 10)$

10. A 6th grade classroom has 13 boys and 16 girls. The teacher randomly chooses two persons to be responsible for the cleanup after a bake sale. Give these probabilities to the tenth of a percent.

- a. What is the probability that both are girls?
- b. What is the probability that both are boys?
- c. What is the probability that the first person chosen is a girl, and the second is a boy?
- d. What is the probability that the first person chosen is a boy, and the second is a girl?

CHECK. The probabilities you get in (a), (b), (c), and (d) should total 100% because they are all the possible outcomes.

- e. Add the probabilities in (c) and (d) to get the probability that one of the cleaners is a girl and one is a boy.

11. Michael has 10 white socks and 14 black socks mixed together in a drawer. He chooses one sock to wear randomly, and doesn't put it back. Then he chooses another sock. Find the probabilities:

- a.  $P(\text{white, white})$
- b.  $P(\text{black, black})$
- c.  $P(\text{black, white})$
- d.  $P(\text{white, black})$

CHECK. The four probabilities above should total 100%.

- e. Add the probabilities in (a) and (b) to find the probability that Michael wears matching socks.
- f. What is the probability Michael doesn't wear matching socks?

### Puzzle Corner

Matthew has 8 white socks, 9 brown socks, and 10 black socks mixed together in a drawer. He chooses two socks randomly. Find the probability he gets to wear a matching pair. (That would be nice!)

(This page intentionally left blank.)

## Using Mean, Median, and Mode

**Example 1.** The two bar graphs show the grades that two classes, 6-A and 6-B, got for science. Which class did better, generally speaking? Can you determine that just from the bar graphs?

You can probably figure out the answer just by looking at the graphs, but we can make sure by finding the median of both data sets. (We cannot find the mean because the data isn't numerical.)

To find the median, we list the students' grades from smallest to the greatest, using the graph.

For class 6-A :

F, D-, D-, D+, D+, D+, C-, C-, C-, C-, C-, C-, C, C, C, C+, C+, C+, C+, C+, B-, B-, B-, B-, B, B, B+, B+, B+, B+, A-, A-, A.

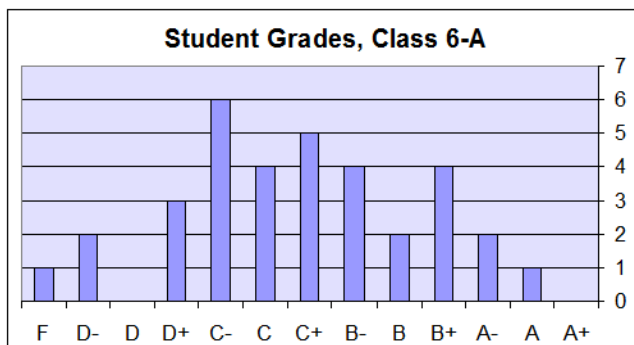

Since there are 34 data entries, the exact middle one doesn't exist as such—both the 17th and 18th entries (C+ and C+) are equally “in the middle.” In such a case, the median is the average of those two. And while we cannot calculate the average when the data entries are not numbers, clearly the “middle point” of C+ and C+ is C+. So the median is C+.

For class 6-B, we have these 35 grades:

F, F, D-, D-, D, D, D, D, D+, D+, D+, D+, D+, D+, D+, C-, C-, C-, C-, C-, C-, C, C, C, C+, C+, C+, C+, B-, B-, B-, B-, B, B.

This time the middle item is the 18th, or C-.

Since the median for class 6-A is C+ and the median for class 6-B is C-, class 6-A did better on average. This can also be seen in the graphs: the bars in the graph for 6-B are more concentrated towards the left than in the graph for 6-A.

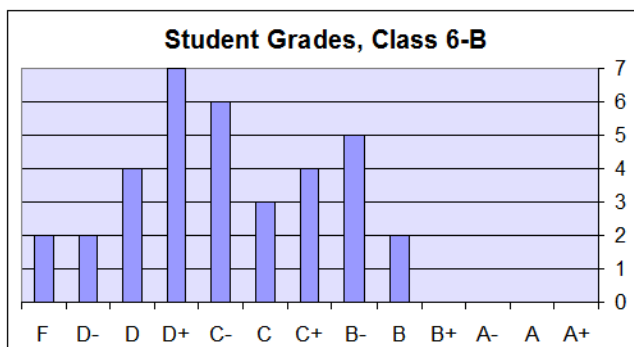

**Example 2.** Consider this data set: 3, 4, 4, 5, 5, 5, 5, 6, 8. Clearly, the median is 5, the mode is 5,

and the mean is  $\frac{3+4+4+5+5+5+5+6+8}{9} = 5$ .

Now, let's say we add ONE more data item to the set (25). Perhaps this is a typing error, but it could also be a true data item, just very different from the others. Since it is very different from the other data points, it is called an **outlier**.

The data set is now 3, 4, 4, 5, 5, 5, 5, 6, 8, 25. How are mean, median, and mode affected by this one additional data item?

Mode is still 5. Median is still 5. But mean becomes  $\frac{3+4+4+5+5+5+5+6+8+25}{10} = 7$ .

In other words, mean was affected greatly by this outlier, whereas mode and median were not.

1. Mrs. Ross gave her students several quizzes in the calculus class. The graphs for the scores are below.

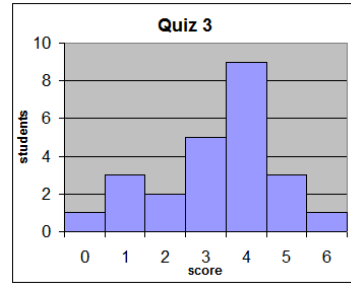
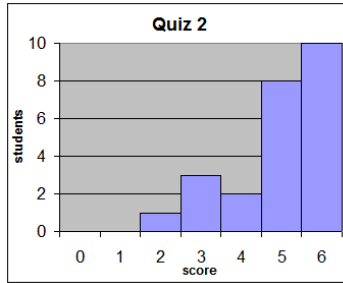
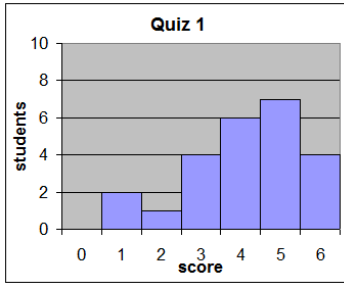

- Mrs. Ross felt one of the quizzes turned out too easy (the students didn't!). Which one?
- The mean scores for the three quizzes were: 3.29, 4.13, and 4.96. Match each mean with the correct graph.
- The median scores for the three quizzes were: 5, 4, and 4. Match each median with the correct graph.
- In which quiz did the students fare the worst?

2. The following are the science grades of two 7th grade classes.

- Make bar graphs from the data.
- Find the mean, median, and mode for the grades of class A and class B.



Class 7-A	
Grades	Students
1	5
2	8
3	7
4	5
5	2

Class 7-B	
Grades	Students
1	3
2	6
3	7
4	7
5	4

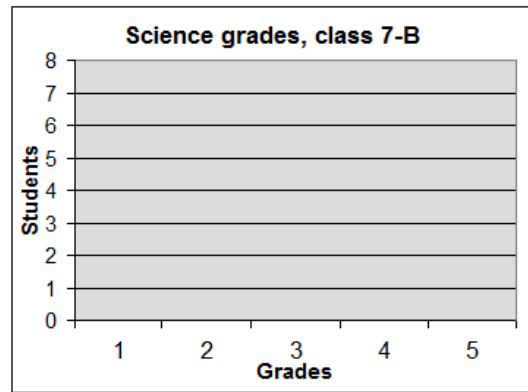
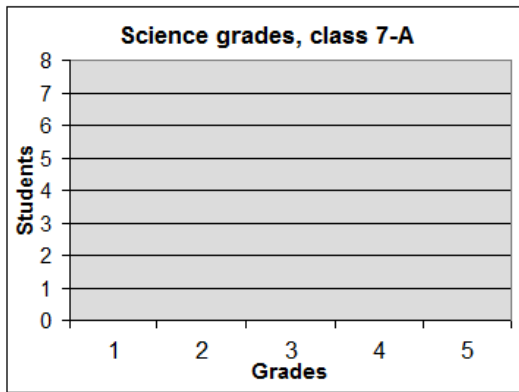

Class A:  
 mean \_\_\_\_\_  
 median \_\_\_\_\_  
 mode \_\_\_\_\_

Class B:  
 mean \_\_\_\_\_  
 median \_\_\_\_\_  
 mode \_\_\_\_\_

- Determine which class did better. Explain your reasoning.

3. a. The following data sets have an outlier. Find the mean, median, and mode for the data sets with and without the outlier.



8, 9, 11, 11, 12, 12, 12, 13, 13, 15, 18, 40	<b>with the outlier</b>	<b>without the outlier</b>
	mean _____	mean _____
	median _____	median _____
-5, 2, 3, 3, 4, 4, 4, 4, 5, 7	<b>with the outlier</b>	<b>without the outlier</b>
	mean _____	mean _____
	median _____	median _____
	mode _____	mode _____

- b. Which of the three measures for central tendency is easily affected by an outlier?

Which are “resistant”, in other words, not easily affected by an outlier?

4. Mean or median? This graph shows the hourly wages of the 89 employees in the Inkypress Print Shop, in euros per hour.

Notice that this graph does not have a “hill” shape, nor any “middle peak”. It's more like one side of a mountain. About half of the people there earn 7-8 euros/hour.

The mean is 9.66 euros/hour and the median is 8 euros/hour.

Is mean or median better in describing the majority's wages in this print shop?

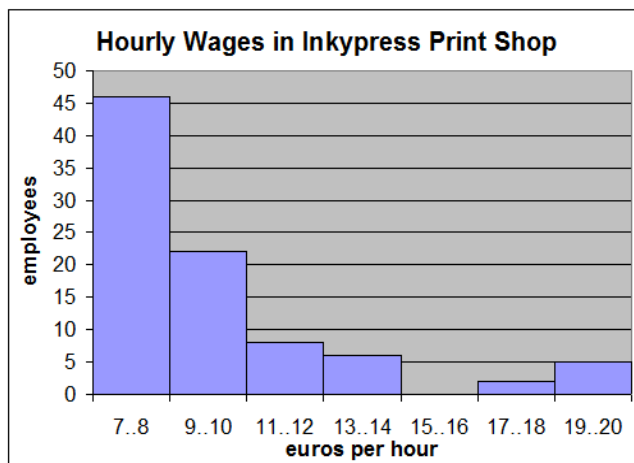

5. Judith surveyed 55 teenagers about how much money they spent to purchase mother's day gifts. Her results are shown in the histogram.

- a. Which of the numbers \$11 and \$9 is the mean? Which is the median?

- b. Would mean or median better describe this data?

- c. About how many percent of the teenagers spent less than \$10 on a mother's day gift?

