

Surface Area

Surface area of a solid means the total area of all of its faces.

So, to calculate the surface area, simply find the area of each face, and add those.

Sometimes the **net** of a solid helps us with that. The net shows all the faces of the solid drawn in a plane—as if on a flat paper—and you can build the solid from the net by folding.

The net of a circular right cone always has a circle as a base. Then, it has a partially drawn circle (sector of a circle) that is the **lateral** face, or the face that “wraps around” the base.

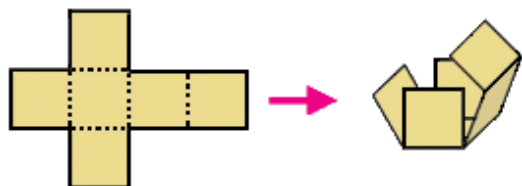

The net of a cube, and it being folded into a cube.

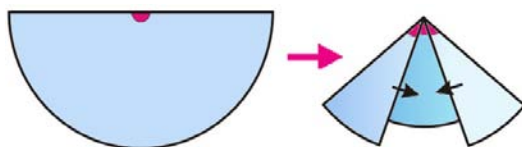

Folding the lateral face of the cone.

Example 1. Find the surface area of the cone with this net.

1. The bottom face is a circle with a radius of 2.25 cm.
Its area is $\pi \times (2.25 \text{ cm})^2 \approx 15.89625 \text{ cm}^2$.
2. The lateral face is a half circle, with a radius of 4.5 cm.
Its area is $0.5 \times \pi \times (4.5 \text{ cm})^2 \approx 31.7925 \text{ cm}^2$.

Lastly we add the two: $15.89625 \text{ cm}^2 + 31.7925 \text{ cm}^2 = 47.68875 \text{ cm}^2 \approx 48 \text{ cm}^2$.

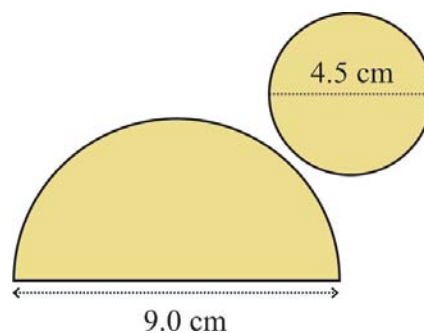

Notice we kept many more decimals for the intermediate results than for our final answer. Don't round your intermediate results very much—do the rounding to the final accuracy only on the final answer.

Example 2. Calculate the surface area of this rectangular prism.

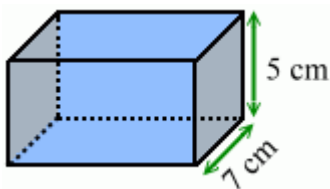

The two faces on the ends are congruent (identical). Each of them has an area of $7 \text{ cm} \times 5 \text{ cm} = 35 \text{ cm}^2$.

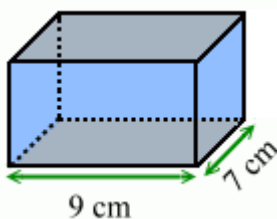

The two faces on the top and bottom are congruent. Each has an area of $9 \text{ cm} \times 7 \text{ cm} = 63 \text{ cm}^2$.

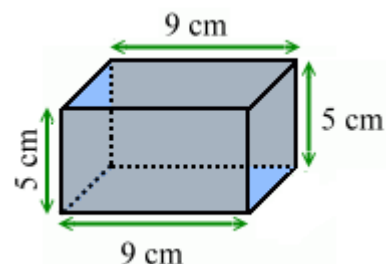

The two faces on the front and back are also congruent. Each has an area of $9 \text{ cm} \times 5 \text{ cm} = 45 \text{ cm}^2$.

So the total surface area is:

$$2 \times 35 \text{ cm}^2 + 2 \times 63 \text{ cm}^2 + 2 \times 45 \text{ cm}^2 = 70 \text{ cm}^2 + 126 \text{ cm}^2 + 90 \text{ cm}^2 = 286 \text{ cm}^2.$$



1. Find the surface area of these water tanks.

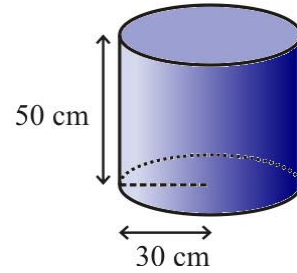
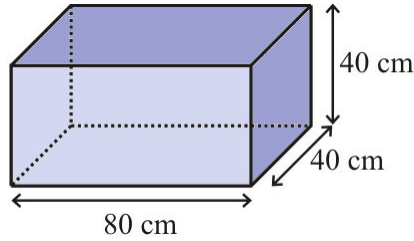
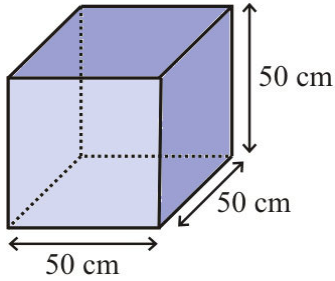

a. _____ cm^2 b. _____ cm^2 c. _____ cm^2

2. Note that $1 \text{ m}^2 = (100 \text{ cm} \times 100 \text{ cm}) = 10,000 \text{ cm}^2$. Use that to convert the surface areas of the water tanks into square meters.

a. _____ m^2 b. _____ m^2 c. _____ m^2

3. Find the volume of the water tanks in exercise #1.

a. _____ cm^3 b. _____ cm^3 c. _____ cm^3

4. We know that $1,000 \text{ cm}^3 = 1,000 \text{ ml} = 1 \text{ liter}$. Use that to convert the volumes of the water tanks into liters.

a. _____ l b. _____ l c. _____ l

5. Name the solids that can be built from these nets, and calculate their surface area.

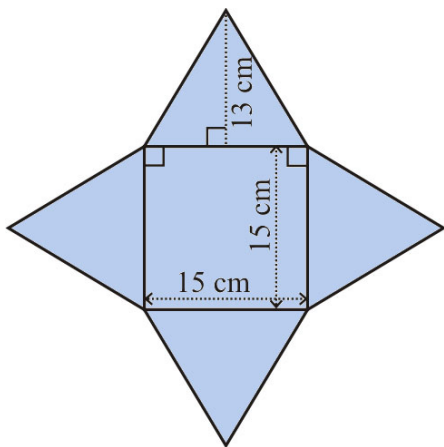

a.
solid: _____
surface area: _____

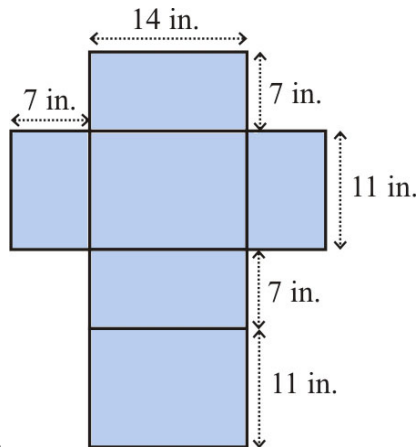

b.
solid: _____
surface area: _____

6. Find the surface areas.

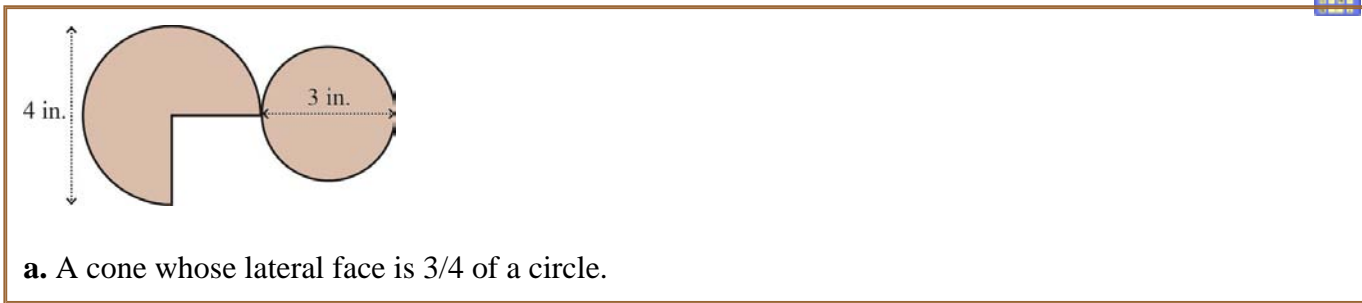

a. A cone whose lateral face is $\frac{3}{4}$ of a circle.



b. A triangular prism

7. A swimming pool is in the shape of a rectangular prism. It is 12.5 m long, 6 m wide, and 2 m deep.



a. Find the surface area of the pool's bottom and sides (not including the top, since it is not covered).

b. Tile costs \$9.90 per square meter. Calculate the cost of tiling the pool.

8. A gift box is in a shape of a cube with 20-cm sides. Calculate its surface area.

9. One cube has a side of 1 unit, and another cube has a side of 2 units. This means that their sides are in the ratio of 1:2.

a. In what ratio are their surface areas?

b. In what ratio are their volumes?

Puzzle Corner

The surface area of a cube is 150 cm^2 . Calculate the volume of the cube.